

Agilent E1442A 64-Channel Form C or Form A Switch

Data Sheet

- 1-Slot, C-size, register based
- Any combination of channels can be closed or opened
- Nonlatching armature relays
- External devices can be actuated
- Includes QUIC easy-to-use terminal block
- Internal buses simplify wiring

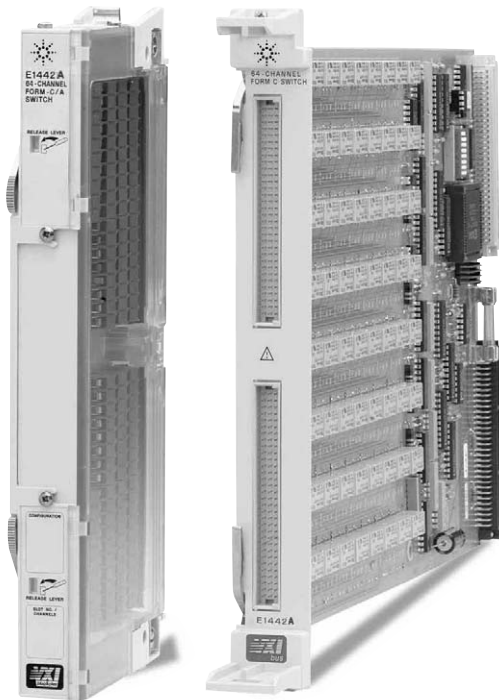

Agilent E1442A

Description

The Agilent E1442A 64-Channel General-Purpose Switch is a **C-size, 1-slot, register-based VXI module** that contains nonlatching Form C type relays. They can be used for device actuation, as digital output modules, or to create flexible signal switching topologies.

Each product has two parts—a component card containing the relays, that plugs into the mainframe, and a removable terminal block that plugs onto the component card. The component card has 64 Form C relays with three independent axial component locations per relay. These locations can be used for jumpers, fuses, or pullup/down and protection resistors. All three relay terminals can be connected through such components to one of three internal buses.

The E1442A terminal block comes standard with solder lugs that allow full access to the Form C (SPDT) capability of the component module relays. Option 020 has a screw terminal block that allows access to the Form A (SPST) contacts only. Option 010 gives you complete Form C connectivity with more customization versatility.

Refer to the Agilent Technologies Website for instrument driver availability and downloading instructions, as well as for recent product updates, if applicable.



Agilent Technologies

Product Specifications

Input

Maximum voltage (C to NC or NO or any terminal-to-chassis):

DC:	150 V
AC rms:	150 V
AC peak:	210 V

Maximum current (noninductive, per switch):

DC:	1 A
AC rms:	1 A

Maximum power:

Per switch:

DC:	40 W
AC:	40 VA

Per module:

DC:	320 W
AC:	320 VA

DC

Maximum thermal offset: 70 μ V

Closed channel resistance:

Initial:	<1.5 Ω typical
End of life:	<3.5 Ω

Insulation resistance (between any two points):

$\leq 40^{\circ}\text{C}$, $\leq 65\%$ RH:	n/a
$\leq 40^{\circ}\text{C}$, $\leq 95\%$ RH:	>10E7 Ω
$\leq 25^{\circ}\text{C}$, $\leq 40\%$ RH:	>10E8 Ω

AC

Typical bandwidth (-3 dB): 10 MHz

Crosstalk (dB, channel-to-channel):

<10 kHz:	n/a
<100 kHz:	<-70
<1 MHz:	n/a
<10 MHz:	<-28

Closed Channel Capacitance

Ch-to-ch:	<30 pF
Ch-to-com:	<40 pF

General

Typical relay life (number of operations):

No load: >5x10E6

Rated load: >10E5

Time to close or open a channel (register programming): 13 ms

Connector type, wire size:

Standard: 2 DIN-Cs with solder lugs Opt 010: solder eyes

Screw: ≥ 18 AWG (1.2 mm), Opt 020

Power up/down states: All open, i.e., nonlatching

Terminal Block

Connection types:

Standard: Solder lug connectors

E1442A with Opt 010: Replaces standard terminal block with provision to add dual 96-pin DIN-C connectors or solder wires directly to terminal block pc board, 0.055 moh holes, 20 AWG max. recommended.

E1442A with Opt 020: Replaces standard terminal block with screw terminals for com and no contacts only, 16 AWG (1.5 mm) max.

General Specifications

VXI Characteristics

VXI device type:	Register based, A16, slave only
Size:	C
Slots:	1
Connectors:	P1/2
Shared memory:	None
VXI busses:	None
C-size compatibility:	n/a

Instrument Drivers

See the *Agilent Technologies Website* (http://www.agilent.com/find/inst_drivers) for driver availability and downloading.

Command module firmware:	Downloadable
Command module firmware rev:	A.06
I-SCPI Win 3.1:	Yes
I-SCPI Series 700:	Yes
C-SCPI LynxOS:	Yes
C-SCPI Series 700:	Yes
Panel Drivers:	Yes
VXIplug&play Win Framework:	Yes
VXIplug&play Win 95/NT Framework:	Yes
VXIplug&play HP-UX Framework:	No

Module Current

	I_{PM}	I_{PM}
+5 V:	0.1	0.11
+12 V:	0	0
-12 V:	0	0
+24 V:	0	0
-24 V:	0	0
-5.2 V:	0	0
-2 V:	0	0

Cooling/Slot

Watts/slot:	5.00
ΔP mm H₂O:	0.15
Air flow liter/s:	0.42

Ordering Information

Description	Product No.
64-Channel Form C/A Switch w/QUIC Interface	E1442A
Form C Switch, QUIC interface, solder terminal block with pull-up/pull-down resistor dividers	E1442A 010
Form A Switch, QUIC interface, screw terminal block	E1442A 020
Same as standard E1442A except replaces QUIC interface with "old style" terminal block and front panel	E1442A 106
Same as E1442A Option 010 except replaces QUIC interface with "old style" terminal block and front panel	E1442A 116
Same as E1442A Option 020 except replaces QUIC interface with "old style" terminal block and front panel	E1442A 126
Service Manual	E1442A 0B3

Ordering Instructions

If you want...

- a Form C switch, QUIC interface and solder terminal block, please order the E1442A.
- a Form C switch, QUIC interface and solder terminal block with pull up/pull down resistive divider, order the E1442A with Option 010.
- a Form A switch, QUIC interface and screw terminal block, order the E1442A with Option 020.

Note:

- The E1442A Option 106 is the same as the standard E1442A, but with the "old style" terminal block & front panel.
- The E1442A Option 116 is the same as the E1442A Opt. 010, but with the "old style" terminal block & front panel.
- The E1442A Option 126 is the same as the E1442A Option 020, but with the "old style" terminal block & front panel.
- There is not an option to order pull up/pull down resistive dividers with the Form A option, and there is not an option to order Form C with screw terminal block.

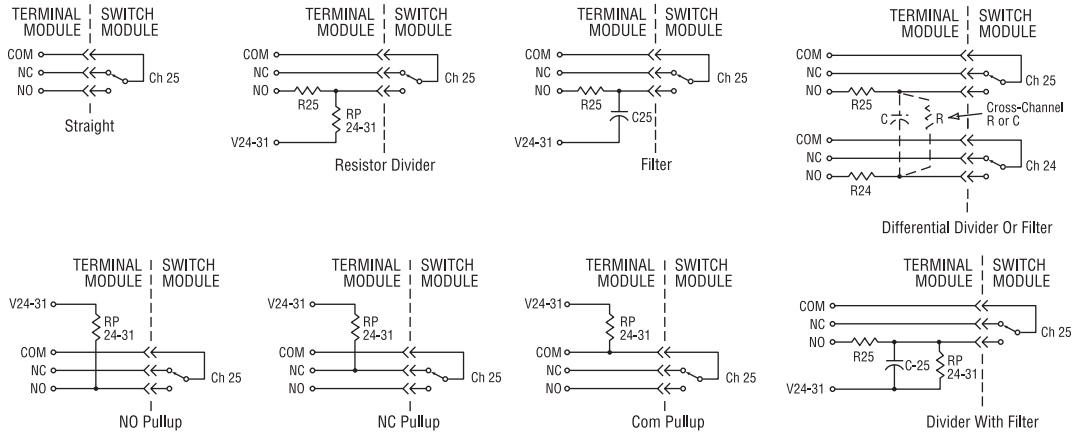

Option 010 Connection Examples

E1442A Option 010 Circuit Diagram

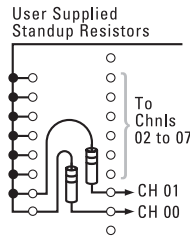

Component Module Channels

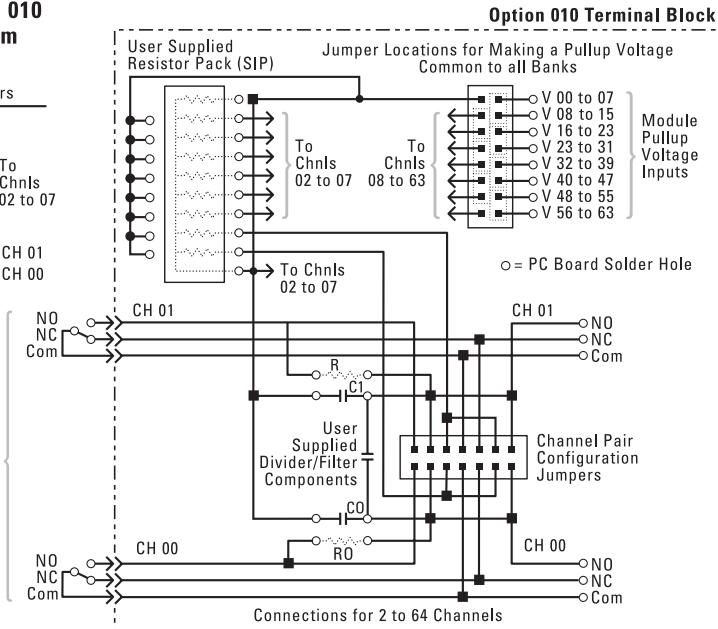

Note: User Supplied Pullup resistors can be either
a) Discrete Standup or b) Resistor Pack

Agilent E1442A Option 010 Block Diagram

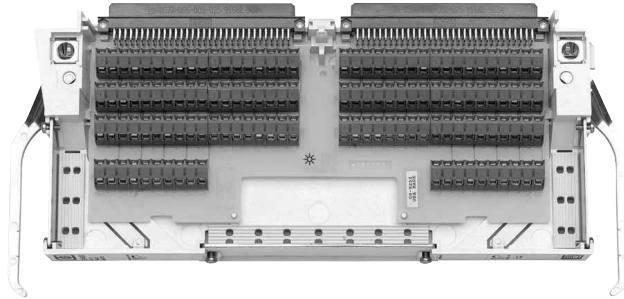

Agilent E1442A Option 020 Terminal Block: Form A Configuration with screw terminals and QUIC interface.

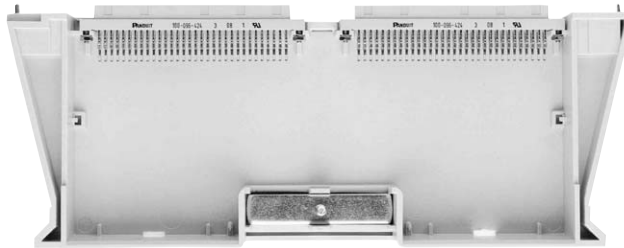

Agilent E1442A Option 106 Terminal Block: Form C Configuration with solder lugs and "old style" interface.

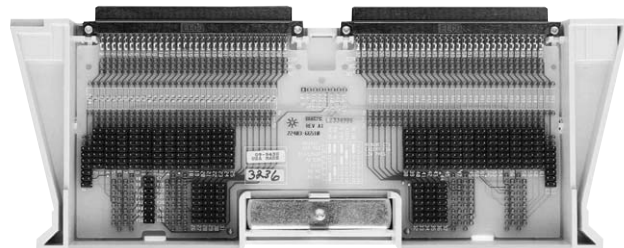

Agilent E1442A Option 116 Terminal Block: Form C Configuration with solder terminal block with pull up/pull down resistors and "old style" interface.

E1442A Block Diagram

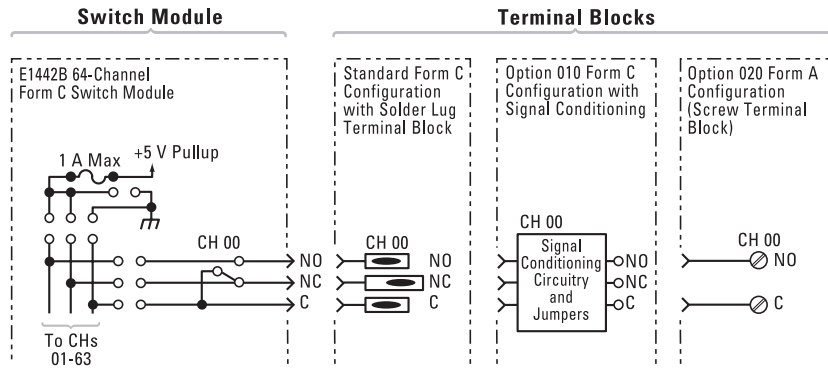

Agilent E1442A Block Diagram

Agilent Technologies' Test and Measurement Support, Services, and Assistance

Agilent Technologies aims to maximize the value you receive, while minimizing your risk and problems. We strive to ensure that you get the test and measurement capabilities you paid for and obtain the support you need. Our extensive support resources and services can help you choose the right Agilent products for your applications and apply them successfully. Every instrument and system we sell has a global warranty. Two concepts underlie Agilent's overall support policy: "Our Promise" and "Your Advantage."

Our Promise

Our Promise means your Agilent test and measurement equipment will meet its advertised performance and functionality. When you are choosing new equipment, we will help you with product information, including realistic performance specifications and practical recommendations from experienced test engineers. When you receive your new Agilent equipment, we can help verify that it works properly, and help with initial product operation.

Your Advantage

Your Advantage means that Agilent offers a wide range of additional expert test and measurement services, which you can purchase according to your unique technical and business needs. Solve problems efficiently and gain a competitive edge by contracting with us for calibration, extra-cost upgrades, out-of-warranty repairs, and onsite education and training, as well as design, system integration, project management, and other professional engineering services. Experienced Agilent engineers and technicians worldwide can help you maximize your productivity, optimize the return on investment of your Agilent instruments and systems, and obtain dependable measurement accuracy for the life of those products.



Agilent Email Updates

www.agilent.com/find/emailupdates

Get the latest information on the products and applications you select.

Agilent T&M Software and Connectivity

Agilent's Test and Measurement software and connectivity products, solutions and developer network allows you to take time out of connecting your instruments to your computer with tools based on PC standards, so you can focus on your tasks, not on your connections.

Visit www.agilent.com/find/connectivity for more information.

For more assistance with all your test and measurement needs or to find your local Agilent office go to www.agilent.com/find/assist

Product specifications and descriptions in this document subject to change without notice.

© Agilent Technologies, Inc. 2005
Printed in the USA May 1, 2005
5965-5588E



Agilent Technologies